

VPENJALNI CILINDRI SERIJA PCAMK

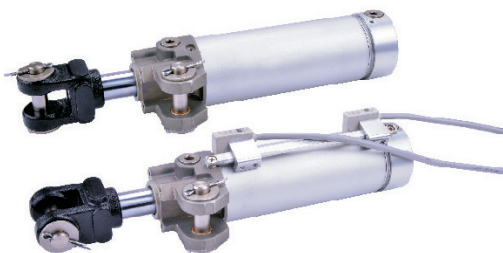

SIMBOL

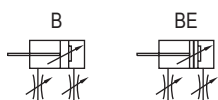

VELIKOST BATA	25	32	40	50	63	80
OSNOVNA IZVEDBA	Dvosmerno delujoči					
MEDIJ	Filtriran zrak 20 μ					
TEMPERATURNO OBMOČJE	-20 / +70°C					
DELOVNI TLAK	1.5 - 10.0 bar					
HITROST	50 - 500 mm/s					
NASTAVITEV DUŠENJA IN HITROSTI	Elastični dušilni obroči	Nastavljivo pnevmatično dušenje na zadnjem pokrovu + obojestranska regulacija hitrosti				
VRSTA MONTAŽE	Dvojna vrtilna vilica					
VELIKOST PRIKLJUČKA	G 1/8		G 1/4		G 3/8	
STANDARDNI HOD	50, 75, 100, 125, 150					

KODA ZA NAROČILO

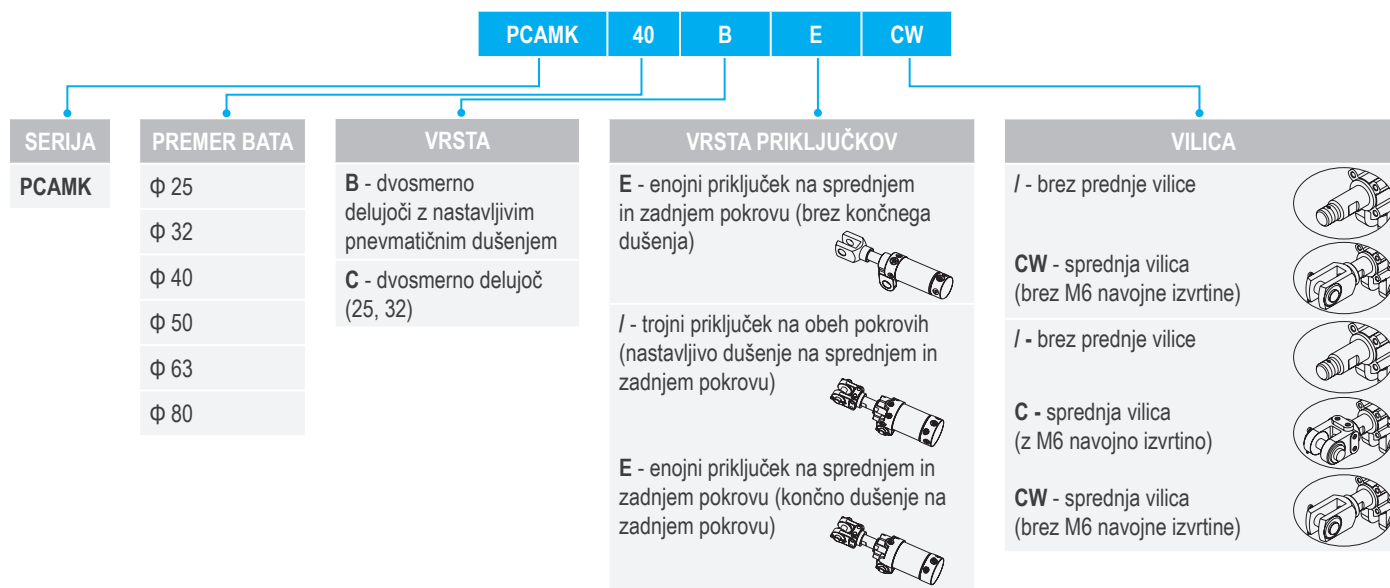

DIMENZIJE

PCAMK

B: Brez magneta
Φ 25

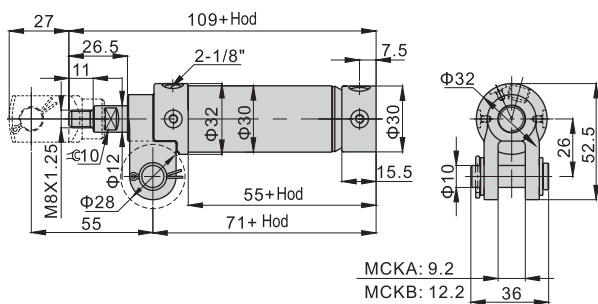

BE: Z magnetom
Φ 25

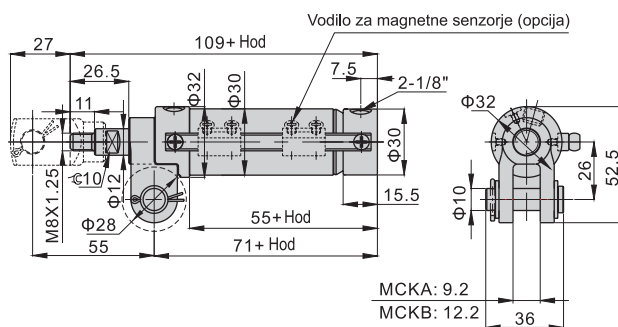

B: Brez magneteta
Φ 32

BE: Z magnetom
Φ 32

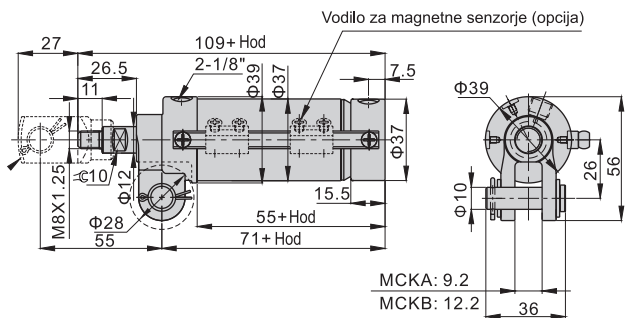
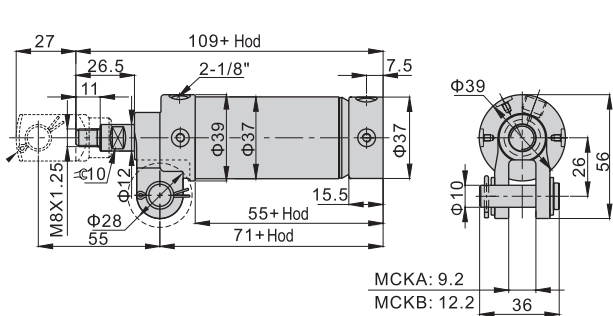

B: Brez magneteta
Φ 40/50/63

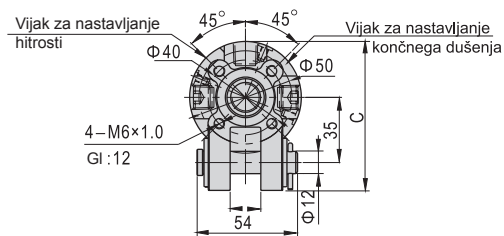
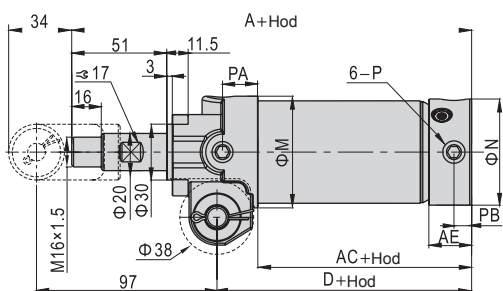

BE: Z magnetom
Φ 40/50/63

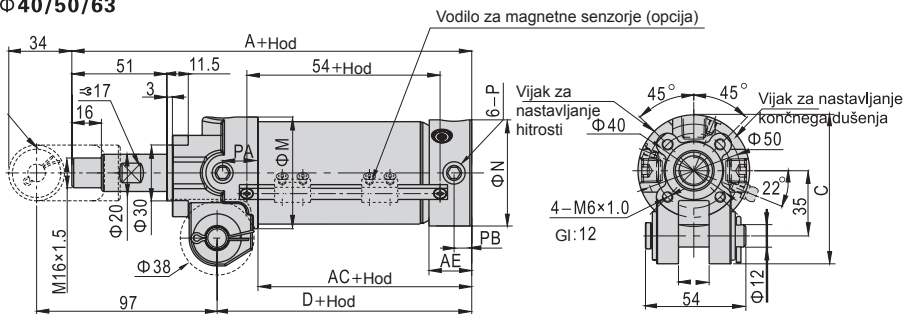

MERA	A	AC	AE	C	D	M
Φ 40	162	59	21	76	84	52
Φ 50	165	65	22	80	87	60
Φ 63	167	67	23	87	89	74

MERA	N	P	PA	PB
Φ 40	47	G 1/4	20	9
Φ 50	57	G 1/4	19	9.5
Φ 63	70	G 1/4	19	9.5

B: Brez magneteta
Φ 80

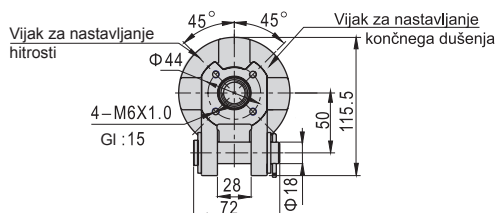
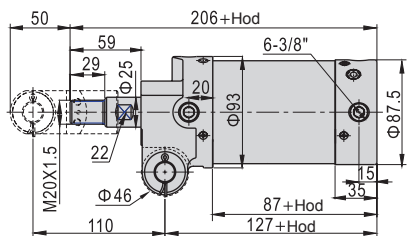

BE: Z magnetom
Φ 80

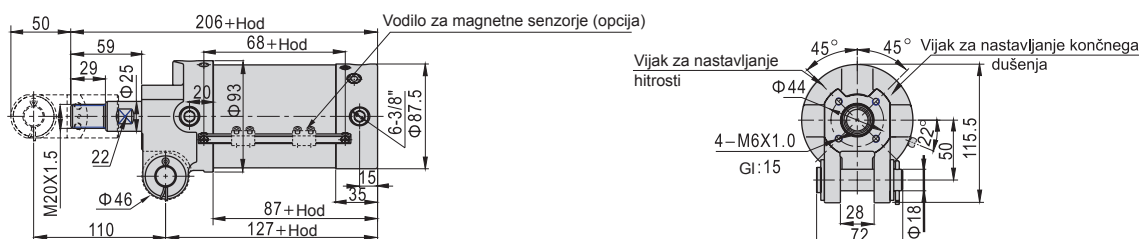

C PCAMK 25 VILICA

Φ 25/32

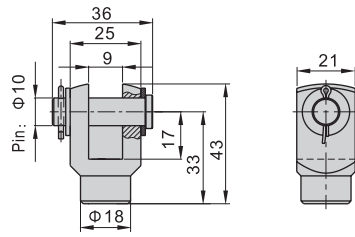

C PCAMK 50 VILICA

Φ 40/50/63

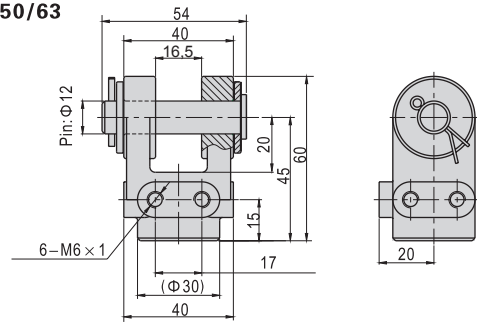

C PCAMK 80 VILICA

Φ 80

